

# TEMPLATE READY CHECKLIST

## » PREPARING FOR TEMPLATE APPOINTMENT



**1.**

All existing countertops must be removed prior to template date unless customer opted to have custom countertop fabricator perform tear out and removal. If old countertop removal is required, it should be cleared.

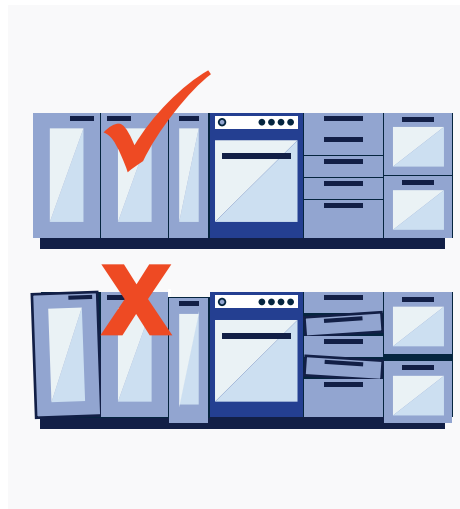

**2.**

All base cabinets and supports must be permanently installed, aligned, leveled within 1/8" on adjoining runs, and anchored or secured to the wall or floor.



**3.**

All end panels, front doors, handles, finish caps, and trim pieces must be in place before template.

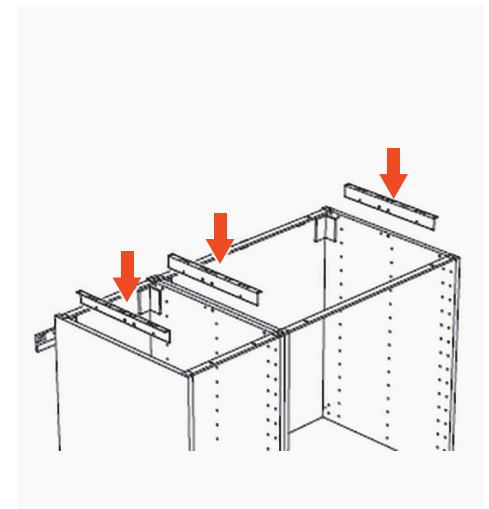

**4.**

FIXA brackets required to be attached to all SEKTION cabinet side gable tops (required for Granite and Quartz countertops).

# TEMPLATE READY CHECKLIST

## » PREPARING FOR TEMPLATE APPOINTMENT

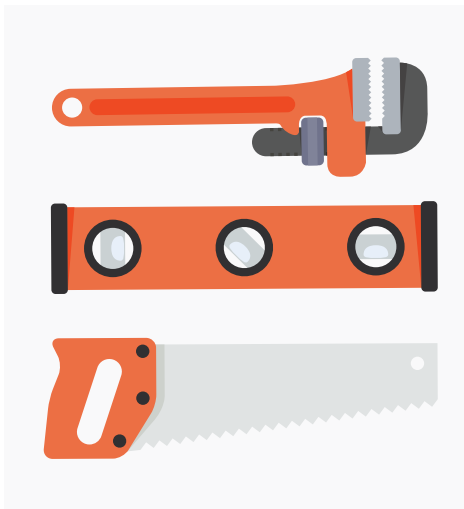

5.

Any leveling, structural repair, plumbing or electrical work is the responsibility of the homeowner.



6.

All items should be removed from under the sink and inside top level cabinets before appointment.

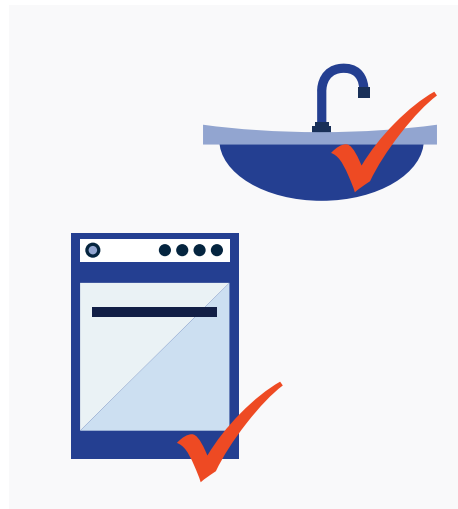

7.

All new or existing sinks, faucets, cooktops, and stoves that shall be installed need to be onsite but unattached and uninstalled at the time of template. Consult with the fabricator regarding dishwasher placement/location. Farmer/Apron sinks need to be propped in final location but uninstalled.



8.

Failure to meet of these conditions will result in an additional charge for a return trip.



# TEMPLATE READY CHECKLIST

» AT TIME OF TEMPLATE APPOINTMENT

## THINGS TO REMEMBER:



A homeowner or authorized designated representative 18 years of age or older must be present during the entire template process. This person will sign off on final dimensions.

Custom countertop fabricator will not proceed without this person of authority present. The appointment will be rescheduled and an additional trip charge will apply.



After template completion, all project details will be considered final and CANNOT be changed.

Confirm installation date with fabricator.



Parking must be provided by customer on template and installation day.



Any deviations from the original project specifications and measurements, provided by the customer in store, may result in a price adjustment.

- **Upcharges:** Fabricator will not proceed with work until so notified by IKEA. Price adjustments will result in the rescheduling of installation date from the time the fabricator receives approval from IKEA to proceed.
- **Refunds:** Fabricator will proceed with work and book installation within 7 business days from time of template.

## FOR ADDITIONAL INFORMATION CONTACT YOUR LOCAL CSR:



PST (Western North America)  
818-205-0126



CST, MST, EST, AST (Mid and Eastern North America)  
1-877-892-5164



# INSTALLATION READY CHECKLIST

## » THINGS TO REMEMBER

- 1** A homeowner or designated representative **18 years of age or older** must be present during the entire installation process. This person must be authorized to approve all work to be completed. Absence of authorized approver will result in appointment cancellation and additional costs.
- 2** **Parking must be provided by customer on installation day.** If fabricator is asked to halt work due to noise requirements, hours, or other restrictions, an additional charge may apply for return trip.
- 3** Prior to installation, **customer must cover anything they want to protect.** The installation process may result in some dust.
- 4** Customer must ensure there is sufficient space through doors or openings that the countertop can fit through. **All pathways must be clear from obstructions.** Countertops are heavy and require a clear and safe path to manoeuvre them during installation.
- 5** **Access to water and electricity in the home is required** for fabricator to complete detailing required.
- 6** Any debris created by the fabricator will be removed and disposed of by the fabricator. **Homeowner is responsible for any debris removal and disposal not created by fabricator.**
- 7** All plumbing and stove/cook-top connections must be **disconnected** and removed prior to installation. Fabricator is not responsible for any situations where plumbing has been reconnected before job completion.
- 8** All sinks must be made available to the fabricator for precise cutting. Please note that **job cannot continue without sink.**
- 9** **Ranges and refrigerators should be moved out of their cabinets** to allow installer free access to all countertop edges. It is the homeowner's responsibility to move and/or disconnect all appliances.
- 10** Homeowner must secure all pets **prior to installation appointment.**
- 11** Under mount sinks need to **cure for 24 hours** before plumbing can be connected.
- 12** Fabricator is **not responsible** for installation of support brackets for overhangs, electrical and plumbing work.